

## TWO-PART STAIR TREADS + NOSINGS

Models: BSTTB, BSTTF, BSTTM

### GENERAL DESCRIPTION



Stair treads and nosings are designed for years of safe egress. Proper installation is critical to the product performance. Locally accepted installation practices and procedures should be followed to ensure a safe stairway system that meets all local code requirements, including Occupational Safety and Health Administration (OSHA), Americans with Disabilities Act (ADA), International Code Council (ICC) and International Building Code (IBC).

### Introduction + Safety

Please read the complete instructions carefully before beginning any work. To ensure proper installation and performance of the product, the following actions must be completed by the installing contractor. Failure to do so will affect product warranty.

**GENERAL SAFETY PRECAUTIONS** Improper selection, installation, or use can cause personal injury or property damage. It is solely the responsibility of the user, through their own analysis, to select products suitable to the specific application requirements, ensure proper maintenance and use as intended. Follow local, state, and federal regulations for proper installation and operation requirements.

### Transportation + Storage

- Inspect all shipments and materials for missing or damaged components and hardware.
- Material must be stored in a clean, dry location.

### Preparation

- Locate the packing slip(s) and/or shop drawings.
- Verify that all products listed on the packing slip are included in the package.
- Check the products for damage. If products are damaged, report a freight claim immediately and leave the products in their packaging. If you sign for products without reporting damage you waive your right to a freight claim and will be responsible for their replacement cost.
- Read the instructions thoroughly before beginning installation.

## Tool List

- Tamping tool
- Screwdriver, Phillips
- Clean-up tools – see Maintenance Section on Cleaning

## INSTALLATION

Slip-resistant metal stair nosings are designed to be fully embedded in the substrate (most often concrete) which provides total support for the nosing. Any voids left between the underside of the metal stair nosing and the substrate will allow flexing of the stair nosing itself. It is vital that the installer tamp down the stair nosings to totally seat into the substrate and fully rest upon any riser return, such as in pan-filled steps. This action will prevent the occurrence of hollows and voids, which can lead to flexing and cantilevering of the nosing.

### Cast-In (Steel Pan Stairs, Poured Concrete or Terrazzo):

1. Pour the concrete.
2. Place the stair nosing bottom with wood insert into position in the concrete. Concrete should be flush with the back of the aluminum, as shown below.

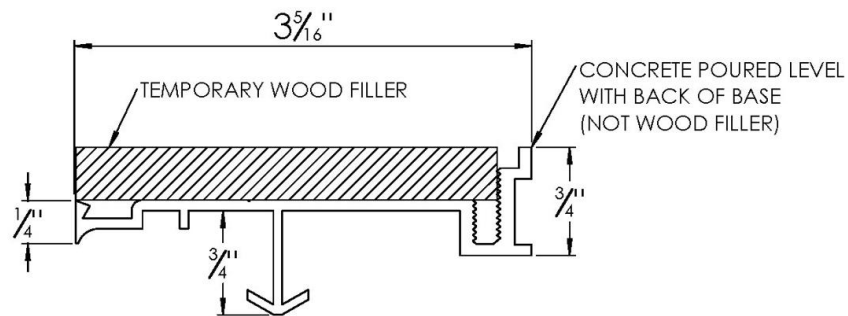

3. Tamp the stair nosing to ensure proper concrete formation around the anchors on the undersides.
4. At the end of construction remove temporary wood inserts and mechanically fasten the slip-resistant top-parts with screws provided with shipment.

## OPERATION

### Photoluminescent Option

Exposure Requirements:

1. The minimum amount of exposure to direct sunlight is 60 minutes.
2. The minimum amount of exposure to artificial ambient illumination is 60 minutes from the following:
  - o Fluorescent straight tube T8 or T12, 4000 – 4500 K color temperature
  - o Incandescent soft white 2700 – 3000 K color temperature
  - o LED 2700 – 3000 K color temperature
3. The control of the ambient illumination necessary to charge the luminous egress path marking system should be restricted to authorized personnel only.
4. Failure to supply the above minimum exposure can prevent the luminous egress path marking from performing as intended.
5. No specific building surface treatment is required for the luminous egress path marking system to function properly.

## MAINTENANCE

Keep stair treads and nosings free of debris and dirt by sweeping or vacuuming regularly. Heavy-duty commercial cleaners will not harm nosings but are generally not necessary. If nosings are damaged, please contact the factory for a repair kit or replacement nosings.

### Cleaning

- Treads should be swept with a broom or vacuumed with a heavy-duty commercial vacuum cleaner at least once a week.
- When needed, scrub surface vigorously with a stiff bristled brush using a mild detergent. **Do not use any product containing solvents, such as Acetone. It will breakdown the abrasive adhesive.** We suggest using Murphy's Oil Soap® or SimpleGreen®. Rinse thoroughly with water after cleaning.
- Scuff marks on the aluminum nose can be removed by rubbing with a fine steel wool and a commercial cleaning agent.
- To remove snow and ice use deicing compounds such as calcium chloride or sodium chloride.
- DO NOT CLEAN ABRASIVE GRIT with PRESSURE WASHER
- EcoTread™ can be pressure washed. Maximum pressure: 3200 psi, 2.5 gpm flow.

## QUESTIONS?

For more information on installation, repair or replacement, please visit [babcockdavis.com](http://babcockdavis.com)